

Problem Session

Static Equilibrium

1. Climbers attempting to cross a stream place a 340-kg log against a vertical, frictionless ice cliff on the opposite side. The log is inclined at 27° , and its center of gravity is one-third of the way along its 6.3-m length. If the coefficient of friction between the left end of the log and the ground is 0.92, what is the maximum mass for a climber and pack to cross without the log slipping?

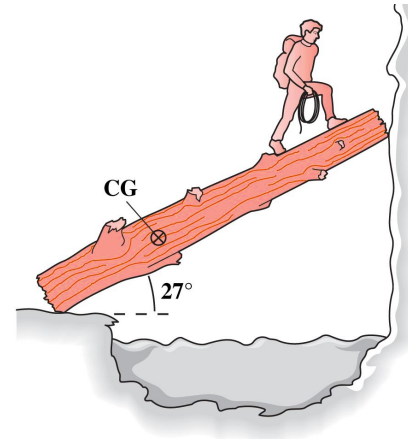

2. The following 300 g block is attached to a 10 N/m spring on an incline plane with a coefficient of static friction of $\mu_s = 0.5$. If the natural length of this spring is 30 cm, find the range of positions from the top of the incline where the block can remain in equilibrium.

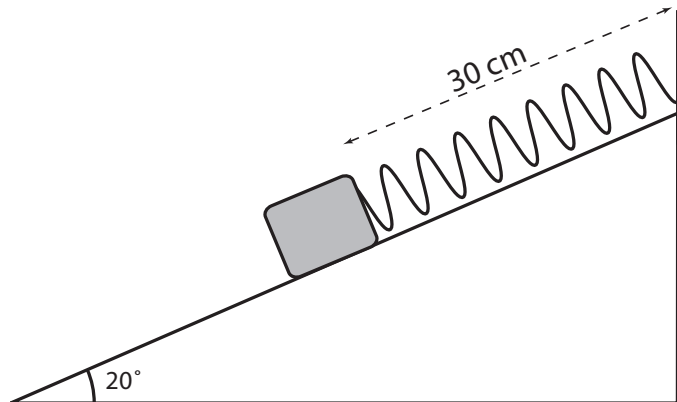

3. A uniform beam of weight 200 N and length 4.0 m (right) is attached to a wall as shown in the diagram below. Calculate the tension in the rope and the contact force at the point P where the beam is fixed to the wall.

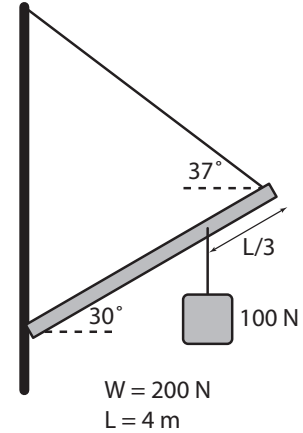

4. Calculate the tension and the contact force on the wall for the beam below of length 4.0 m and weight 5000 N.

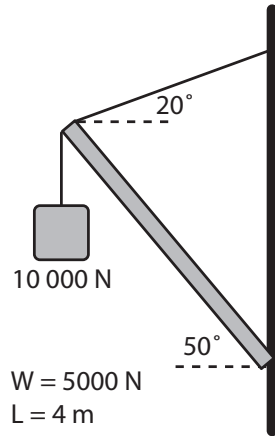

5. Find the force P , T_1 , and T_2 .

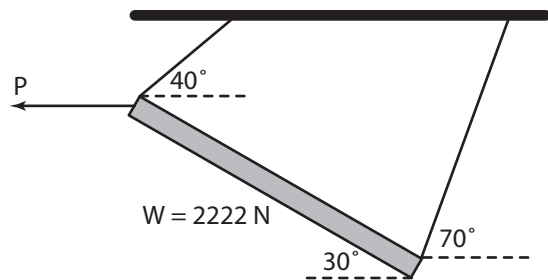

6. A 75 kg man climbs up a 120 N uniform ladder of length 4 m. The ladder rests on a frictionless wall and a frictionless floor, however the lower end of the ladder is fastened to the wall by a horizontal rope which can withstand a maximum tension of 400 N. Find,

- the tension in this rope when the man is one third up the ladder, and
- the maximum distance (d) that the man can climb before the rope breaks.

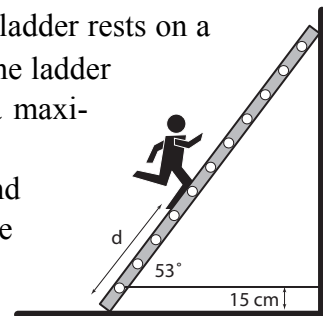

7. Find the force necessary which will just prevent the 20 kg block from sliding up the inclined plane, $W = 400$ N, $\mu_s = 0.5$, and $\theta = 30^\circ$.

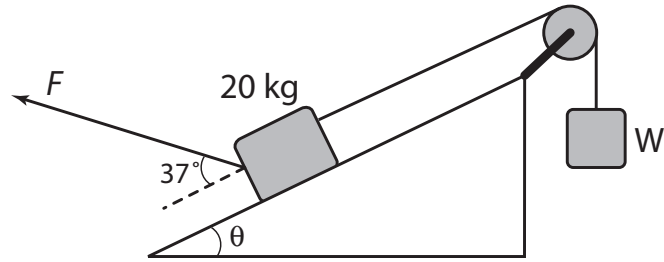

8. The system shown is in equilibrium relying on friction to barely keep the 300 N block from sliding up the inclined plane. Find the tensions along the ropes and μ_s .

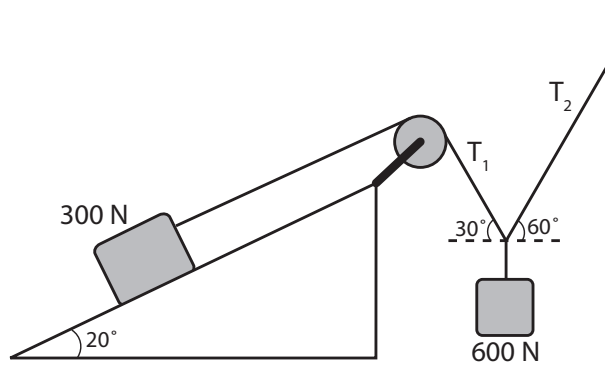

answers

1. $m = 86.7 \text{ kg}$
2. $x_{\max} = 53.9 \text{ cm}; x_{\min} = 26.2 \text{ cm}$
3. $R_x = 125 \text{ N}, R_y = 206 \text{ N}, T = 157 \text{ N}$
4. $R_x = 8035 \text{ N}, R_y = 12076 \text{ N}, T = 8550 \text{ N}$
5. $P = 1888 \text{ N}, T_1 = 2028 \text{ N}, T_2 = 977 \text{ N}$
6. $T = 241 \text{ N}, d_{\max} = 2.43 \text{ m}$
7. $F = 436 \text{ N}$
8. $T_1 = 300 \text{ N}, T_2 = 519 \text{ N}, \mu_s = 0.717$